



EHK18VROTATEKIT

18V Air Cooled Rotating Hot Knife Kit User Manual



- Please read these instructions carefully before operation
- Take special note of the safety prompts in these instructions to avoid injury to yourself, other people and objects.
- Please follow the guidelines in these instructions to avoid damage to the tool

The EHK18VROTATE is the first Cordless, Air-Cooled, Rotating Head Hot Knife in the world, allowing continuous operation of the tool and ergonomic flexibility due to the five available head positions.

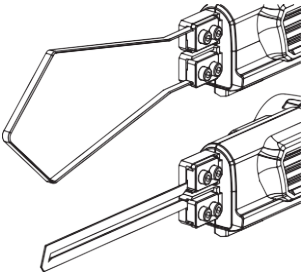
1-844-TT-TOOLS
www.tapetech.com

TapeTech Tools
1327 Northbrook Parkway, Suite 400
Suwanee, GA 30024

INTRODUCTION

The EHK18VROTATE Hot Knife is a professional-grade hot cutting tool for foamed plastics. The EHK18VROTATE Hot Knife heats up in seconds and offers the operator variable temperature control, allowing for easy, mess-free use in a number of materials PLUS the ability to rotate the head to the optimal cutting position.

RECOMMENDED USES



Cutting and shaping of Expanded Polystyrene (EPS), Extruded Polystyrene (XPS), Polyethylene, Cross- Linked Polyethylene, Polypropylenes, and many other foamed plastics and materials. Check with the foam manufacturer for safe and proper cutting procedures. The 2-in-1 pressure plate can be fitted with a straight blade or a flat blade.

BLADE INSTALLATION

NOTE: Always remove the battery of the EHK18VROTATE Hot Knife before installing or removing the blades. Allow sufficient cooling time for blades, blade holders and mounting screws before handling.

IMPORTANT: The EHK18VROTATE blade has a sharpened razor edge. For the cleanest cut, always cut in the direction of the sharpened edge.

To Install the Hot Knife Blade:

1. Loosen the screws on the blade holders with the provided Allen wrench.
2. Slide the blade under the square pressure plates until snug.
3. You can orient the sharpened edge of the blade toward you or away from you. Just remember to cut in the direction of the sharpened edge.
4. Securely tighten screws to assure the proper electrical connection. Do not over-tighten.



CAUTION: DO NOT cover the air intake!

OPERATION

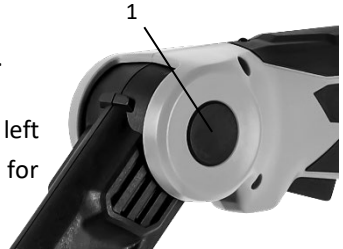
Once the blade is firmly in place, insert the battery into the EHK18VROTATE unit. The temperature control knob has 3 settings. Setting the temperature too high may cause the blade holder to overheat. The blade does not need to be red hot to cut the foam. Settings 1 and 2 are suitable for grooving blades. Setting 3 is suitable for straight blades.



Set the temperature control knob to the proper setting, place the blade against the edge of the foam and depress trigger. Begin moving the blade along the intended cut line. Optimum cutting should be virtually smoke free.

NOTE: For the best results, practice on scrap pieces of foam.

TO ROTATE THE HEAD: Press the black button (1) on the left side of the tool and adjust the head to the optimal position for the cut.



Excessive power output and heat generation may cause the blade holders to overheat resulting in damage to the unit. Use only the power output for proper cutting. The blade does not need to be red hot to move through foamed plastics.

When cutting foam it is best to keep the temperature and speed consistent. If smoke develops during the cut, you are cutting too slowly or the blade is too hot which could result in an oversized, uneven cut. This can be remedied by lowering the temperature and intermittently releasing the trigger during your cut. As the cutting resistance increases, depress the trigger again. The EHK18VROTATE Hot Knife will reach the set temperature within seconds. You can accomplish your cut with minimal smoke using this process. Cutting in this manner will also prolong the life of the knife.

Releasing the trigger approximately one to two inches prior to the end of the cut will help keep the blade clean and free from buildup.

Use the proper length blade for the application. The cutting blade should not extend more than 3/4" past the thickness of the foam. The foam cools the blade as it cuts. The exposed portion can overheat and cause the blade to warp.

CAUTION:

1. Consult the foam manufacturer's MSDS sheet for flash points and material toxicity.
2. Always operate the EHK18VROTATE Hot Knife in well-ventilated space.
3. Never burn off excess residue on the hot knife blade. The blades will overheat, warping the blade and potentially overheating the Hot Knife.
4. Only operate the EHK18VROTATE Hot Knife when it is in contact with the foam.
5. Keep hot blades away from skin, clothing and other flammable materials. A hot blade may cause injury or burns to exposed surfaces.
6. This tool is not suitable for people with health issues, sensory or mental impairment.
7. This tool is not intended for children.
8. Operate the Hot Knife only as instructed. Use gloves and appropriate safety gear when using the tool. Store the tool in a dry place when not in use. Do not use the tool in damp or wet locations.

MAINTENANCE

Continuous use of the EHK18VROTATE Hot Knife may result in polystyrene material build up on blades and the brass holders. This excess polystyrene can interfere with heat transference and impair the performance of the blades. The brass blade holders and blades can be thoroughly cleaned with a wire brush.

Always inspect your device before use. Do not use if the battery or battery contacts are damaged. Tool should be repaired by an authorized technician to avoid injury.

TECHNICAL SPECIFICATIONS

EHK18VROTATE Hot Knife	
Voltage	18V DC
Operation	Continuous Operation
Tool Weight (excluding battery)	1.25 pounds (570g)
Maximum Temperature	932° F (500° C)
BATTERY	
Voltage	18V DC
Capacity	5.0 Ah
Weight	1.3 pounds (595g)
BATTERY CHARGER	
Input Voltage	100 – 120V AC
Output Voltage	21V DC
Optimum Charging Temperature	32° – 104° F (0 – 40° C)
Charging Time	5.0 Ah < 40 minutes
Weight	1.75 pounds (795g)

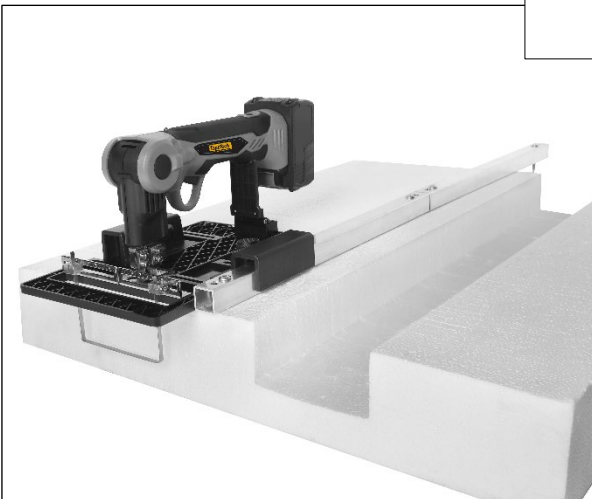
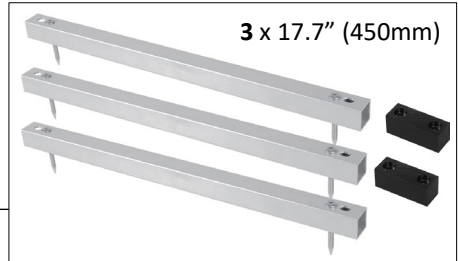
ACCESSORIES AND ADAPTERS

PROFESSIONAL FOAM SLED | Model: ESLED02

The best hot knife sled in the industry is suitable for groove widths between 0.5" – 6.5" (12mm -165mm). The ESLED02 includes a 3-piece guide rail with a total length of more than 52" (1350mm) for precise grooving.

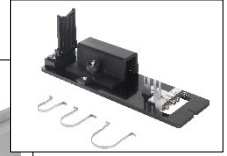


Illustration of Dedicated Guide Rail



PROFESSIONAL GROOVING ADAPTOR | Model: EGBADAPT03

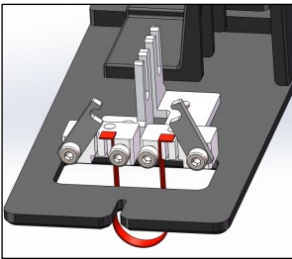
PERFECT FOR pipe grooving blades for open, closed or embedded water pipes and conduit, when used with TapeTech's unique Ω -shaped blades the EGBADAPT features quick and easy installation. There is no need to remove the installation plate or adjust the blade height; just install the grooving blade directly at the bend.



Ω -Shaped Pipe Groovers

EPG20: $\frac{3}{4}$ " (20mm)
EPG27: 1" (27mm)
EPG34: 1.3" (34mm)

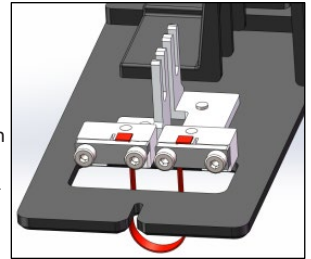
Installation Guide for Ω -shaped Grooving Blades



Using the provided wrench, loosen the set screws and pivot the keeper arms upward.

Slide the groover blade into the slots at the bend in the groover.

Pivot the keeper arms back down and tighten the set screws.



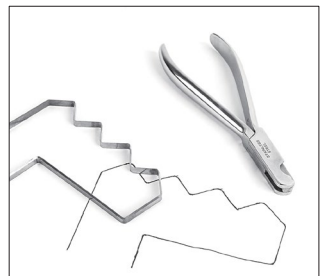
CUTTING GUIDE | Model: EGUIDE02

Adjust the T-shaped ruler of the EGUIDE02 Cutting Guide for precise measurements when cutting. Adjust the angle for vertical cutting or 0° to 45° diagonal cutting.

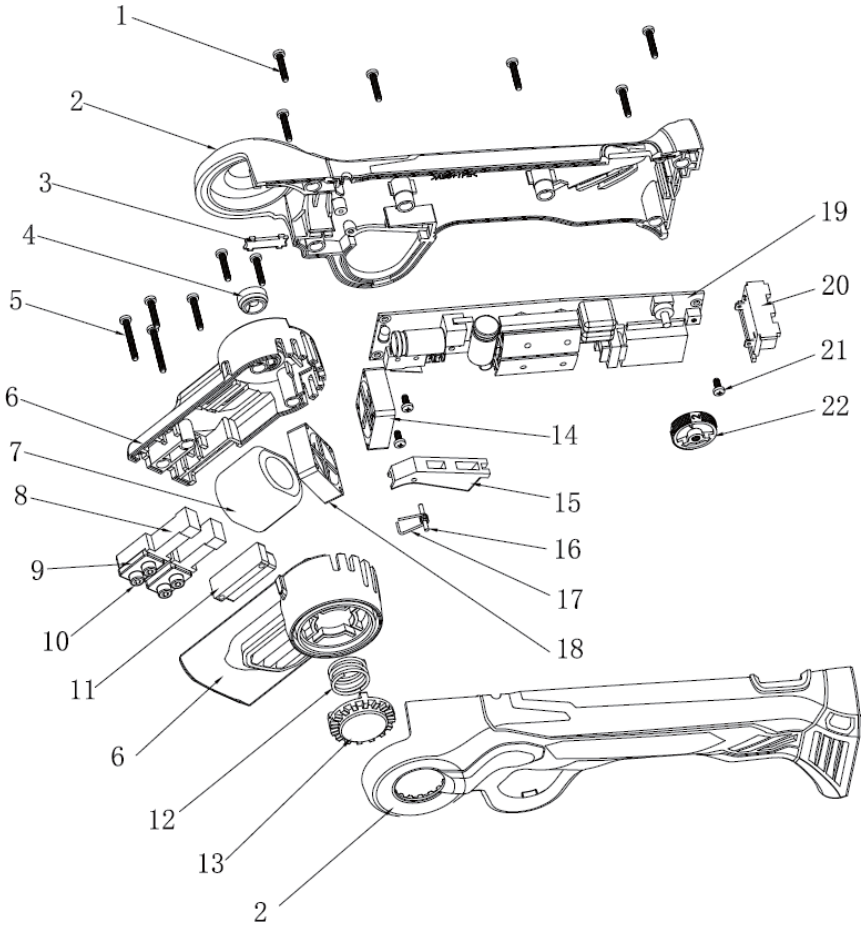


SPECIAL BLADE BENDING PLIERS | Model: EPLIER

Use the special blade bending pliers to quickly and easily fashion grooving blades to match any jobsite specification.



EXPLODED PRODUCT DIAGRAM



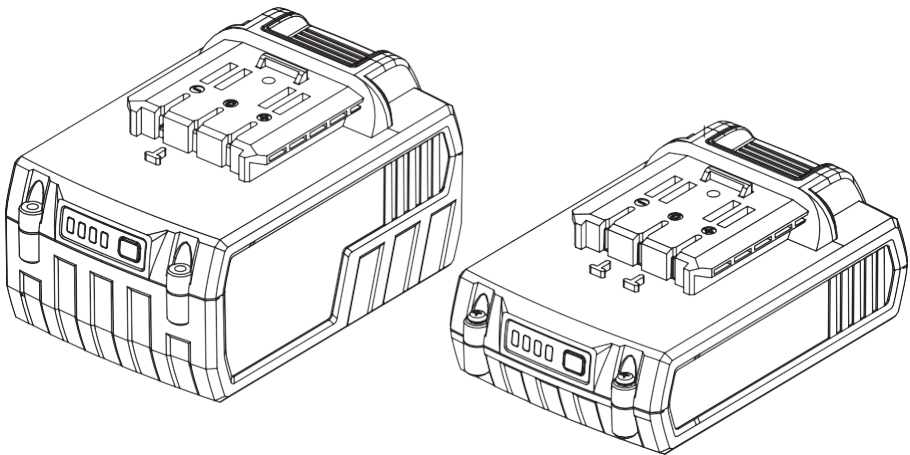
- | | |
|---|-------------------------------|
| 1. Self-tapping Screw, Galvanized, ST3*16 | 12. Locking Button Spring |
| 2. Product Shell | 13. Locking Button |
| 3. Guide Line Pressing Plate | 14. Fan Cable 80mm |
| 4. Rubber Power Cord Clamp | 15. Trigger |
| 5. Self-tapping Screw ST3*25 | 16. Trigger Pin |
| 6. Dual Fan Blade Holder Casing | 17. Trigger Spring |
| 7. Coil | 18. The Fan Wire 150 |
| 8. Blade Holder | 19. PCB Board |
| 9. Blade Holder for sculpture | 20. Electrode Plate |
| 10. Hex Socket Screw, M4*18 | 21. Self-tapping Screw, ST3*6 |
| 11. Bracket Fixing Block | 22. Adjustment Wheel |



EHK18VROTATEKIT

18V Air Cooled Rotating Hot Knife Kit User Manual

18V Li-Ion BATTERIES



1-844-TT-TOOLS
www.tapetech.com

TapeTech Tools
1327 Northbrook Parkway, Suite 400
Suwanee, GA 30024

SAFETY INSTRUCTIONS

Read all safety information and general instructions. Failure to observe the safety information and general instructions may result in electric shock, fire and/or serious injury. Keep all the safety information and general instructions for future reference.

- **These safety warnings apply only for lithium-ion batteries!**
- **Only use the battery with products from the manufacturer.** This is the only way in which you can protect the battery against dangerous overload.
- Recharge the batteries only with the charger specified by the manufacturer. A charger that is suitable for one type of battery pack may create a risk of fire when used with another battery pack.
- **The battery is supplied partially charged.** To ensure full battery capacity, fully charge the battery in the charger before using your power tool for the first time.
- **Keep battery packs out of the reach of children.**
- **Do not open the battery.** There is a risk of short-circuiting.
- **In case of damage and improper use of the battery, vapors may be emitted. The battery can set alight or explode.** Ensure the area is well ventilated and seek medical attention should you experience any adverse effects. The vapors may irritate the respiratory system.
- **If used incorrectly or if the battery is damaged, flammable liquid may be ejected from the battery. Contact with this liquid should be avoided. If contact accidentally occurs, rinse off with water. If the liquid comes into contact with your eyes, seek additional medical attention.** Liquid ejected from the battery may cause irritation or burns.
- **If the battery is damaged, liquid can be ejected and cover nearby surfaces.** Check affected parts. Clean these parts or change them if necessary.
- **Do not short-circuit the battery pack. When the battery pack is not in use, keep it away from other metal objects, like paper clips, coins, keys, nails, screws or other small metal objects, that can make a connection from one terminal to another.** Shorting the battery terminals together may cause burns or a fire.
- **The battery can be damaged by pointed objects such as nails or screwdrivers or by force applied externally.** An internal short circuit may occur, causing the battery to burn, smoke, explode or overheat.
- **Never service damaged battery packs.** Service of battery packs should only be performed by the manufacturer or authorized service providers.
- **Protect the battery against heat, e.g. against continuous intense sunlight, fire, dirt, water and moisture.** There is a risk of explosion and short-circuiting.

- **Only operate and store the battery at an ambient temperature of -4° F to 122° F (-20 °C to +50 °C).** Do not leave the battery in your car in the summer, for example. At temperatures of < 32° F (0 °C), some devices may experience a loss of power.
 - **Only charge the battery at an ambient temperature from 32° F to 114° F (0° C to +45° C).** **Only charge the rechargeable battery with a USB cable at an ambient temperature from 50° F to 90° F (+10°C to +35°C).** Charging outside of this temperature range can increase the risk of damage to the battery and pose a fire hazard.
- Ensure that the battery is charged for at least 5 minutes every 6 months, otherwise it may result in battery damage.

MAINTENANCE AND SERVICE

Maintenance and cleaning for battery

Occasionally clean the ventilation slots and the terminals on the battery using a soft brush that is clean and dry.

Transport

Lithium-ion batteries are subject to the Dangerous Goods Legislation requirements. The batteries are suitable for road-transport by the user without further restrictions. When shipping by third parties (e.g.: by air transport or forwarding agency), special requirements on packaging and labelling must be observed. For preparation of the item being shipped, consulting an expert for hazardous material is required. Dispatch battery packs only when the housing is undamaged. Tape or mask off open contacts and pack up the battery in such a manner that it cannot move around in the packaging. Please also observe the possibility of more detailed national regulations.

Disposal

Do not throw battery pack into the household waste!
 Batteries and packaging should be sorted for environmentally friendly recycling. Please return the damaged battery pack or used battery pack to the dealer. Do not throw battery pack in water! Please discharge the battery pack before handling. Please protect contacts to prevent short circuit. (e.g. use tape for isolation)

Only for EU countries:

According to the Directive 2006/66/EC, defective or used battery packs/batteries, must be collected separately and disposed of in an environmentally correct manner.

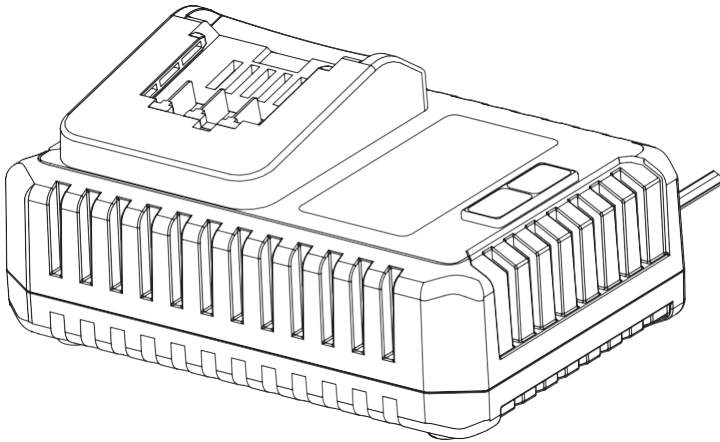
BATTERY TECHNICAL DATA

BATTERY	
Voltage	18V DC
Capacity	5.0 Ah
Weight	1.3 pounds (595g)



EHK18VROTATEKIT
18V Air Cooled Rotating Hot
Knife Kit User Manual

21V BATTERY CHARGER



1-844-TT-TOOLS
www.tapetech.com

TapeTech Tools
1327 Northbrook Parkway, Suite 400
Suwanee, GA 30024

SAFETY INSTRUCTIONS

Read all the safety and general instructions. Failure to observe the safety and general instructions may result in electric shock, fire and/or serious injury. Only use the charger if you can fully evaluate all functions and carry them out without restrictions, or if you have received corresponding instructions.

- This charger is not intended for use by children or persons with physical, sensory or mental limitations or a lack of experience or knowledge. This charger can be used by children aged 8 or older and by persons who have physical, sensory or mental limitations or a lack of experience or knowledge if a person responsible for their safety supervises them or has instructed them in the safe operation of the charger and they understand the associated dangers. Otherwise, there is a risk of operating errors and injuries.

- **Supervise children during use, cleaning and maintenance.** This will ensure that children do not play with the charger.

- **Only charge Li-Ion batteries with a capacity of 2.0 Ah or more (3 battery cells or more).**

The battery voltage must match the battery charging voltage of the charger. Do not charge any non-rechargeable batteries. Otherwise there is a risk of fire and explosion.

Do not expose the charger to rain or wet conditions. Water entering a power tool will increase the risk of electric shock.

- **Keep the charger clean.** Dirt poses a risk of electric shock.

- **Always check the charger, cable and plug before use. Stop using the charger if you discover any damage. Do not open the charger yourself, and have it repaired only by a qualified specialist using only original replacement parts.** Damaged chargers, cables and plugs increase the risk of electric shock.

- **Do not operate the charger on an easily ignited surface (e.g. paper, textiles, etc.) or in a flammable environment.** There is a risk of fire due to the charger heating up during operation.

- **Do not cover the ventilation slots of the charger.** Otherwise, the charger may overheat and no longer function properly.

- **Recharge only with the charger specified by the manufacturer.** A charger that is suitable for one type of battery pack may create a risk of fire when used with another battery pack.

- **In case of damage and improper use of the battery, vapors may also be emitted.**

Ensure the area is well-ventilated and seek medical attention should you experience any adverse effects. The vapors may irritate the respiratory system.

- **Under abusive conditions, liquid may be ejected from the battery; avoid contact. If contact accidentally occurs, flush with water. If liquid contacts eyes, additionally seek medical help.** Liquid ejected from the battery may cause irritation or burns.

PRODUCT DESCRIPTION AND SPECIFICATIONS OF BATTERY CHARGER

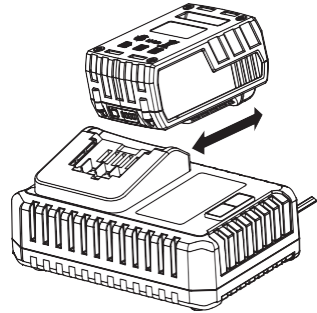
TECHNICAL DATA

BATTERY CHARGER	
Input Voltage	100-120V
Output Voltage	21V DC
Optimum Charging Temperature	32° – 104° F (0 – 40° C)
Charging Time	5.0Ah < 40 minutes
Weight	1.75 pounds (795g)

OPERATION

Before using the tool, charge the battery as follows.

- **Plug the battery charger into the proper AC voltage source.** The voltage of the power source must match the voltage specified on the rating plate of the charger. After plugging in the charger correctly, the power light will display a green light.



CHARGING PROCESS

- The charging process begins as soon as the charger is plugged in to an appropriate power source and the battery is inserted into the charging slot.
- When the battery is inserted fully, the charging light will change to red. At the same time, the power light will go off and charging will begin. The charging light will remain lit steadily during charging.
- When the charging light goes off, the power light changes from Green (Press the button on the battery, four power display lights are on.), the charging cycle is complete.
- After charging, unplug the charger from the power source.
- The charging process is only possible when the temperature of the battery is within the permitted charging temperature range.

PRACTICAL ADVICE

A significantly reduced operating time after charging indicates that the battery has deteriorated and must be replaced. When the charger is used continuously, or for several consecutive charge cycles without interruption, the charger may heat up. This is, however, harmless and does not indicate that the charger has a technical defect.

MAINTENANCE AND SERVICE

MAINTENANCE AND CLEANING FOR BATTERY CHARGER

In order to avoid safety hazards, if the power supply cord needs to be replaced, this must be done by the supplier or by an after-sales service center that is authorized to repair power tools.

DISPOSAL

Chargers, accessories and packaging should be recycled in an environmentally friendly manner. Do not dispose of chargers along with household waste.