



ETURNABLE Material Support Turntable User Manual



1-844-TT-TOOLS
www.tapetech.com

TapeTech Tools
1327 Northbrook Parkway, Suite 400
Suwanee, GA 30024

ETURNTABLE Material Support Turntable Key Components

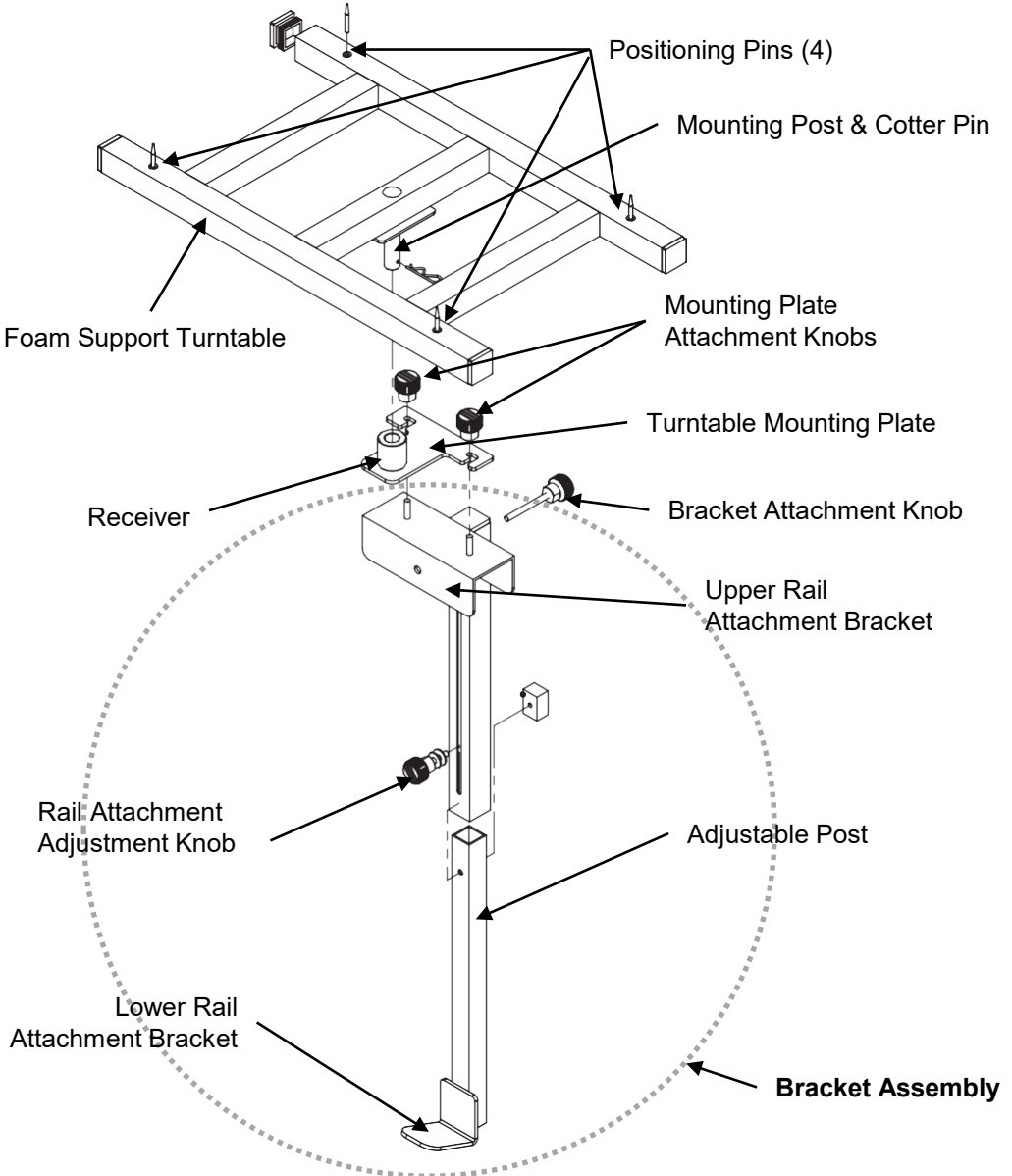

ETURNTABLE Material Support Turntable User Manual

The **TapeTech ETURNTABLE Material Support Turntable** is a professional-grade accessory designed to securely hold EPS/XPS foam panels while cutting, grooving or spreading adhesive when working on a scaffold or swing stage.

Installation of the Turntable to the Scaffold or Swing Stage

A. Attach the Bracket Assembly

1. Slide the Upper Rail Attachment Bracket over the top of the upper rail of the scaffold or stage.
2. Slide the lower end of the Adjustable Post up until the Lower Rail Attachment Bracket hooks the center rail of the scaffold or stage.
3. Tighten the Rail Attachment Adjustment Knob.
4. Tighten the Bracket Attachment Knob to secure the bracket assembly to the upper rail of the scaffold or stage.

B. Attach the Turntable to the Bracket Assembly

1. Slide the Mounting Post of the turntable into the Receiver on the Mounting Plate.
2. Secure the turntable to the Mounting Plate using the Cotter Pin.
3. Slide the slots of the Mounting Plate onto the bolts on the top of the bracket assembly.
4. Tighten the Mounting Plate Adjustment Knobs.

Using the Turntable

1. Position a foam panel on top of the four Positioning Pins
2. Press down to secure the foam panel in place
3. Rotate the turntable to the desired position
4. Complete the cut, groove or material application
5. Remove EPS/XPS foam by lifting the panel off the positioning pins

Specifications

Turntable Width: 12.2" (310mm)

Turntable Length: 21.2" (540mm)

Maximum Allowable Diameter of Rail: 2.125" (54mm)

Minimum Distance Between Rail Centers: 14.2" (360mm)

Maximum Distance Between Rail Centers: 23.2" (590mm)

ETURNTABLE Material Support Turntable – Installed View

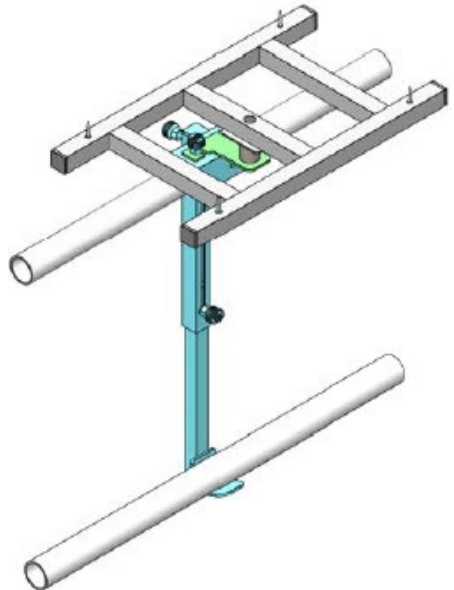
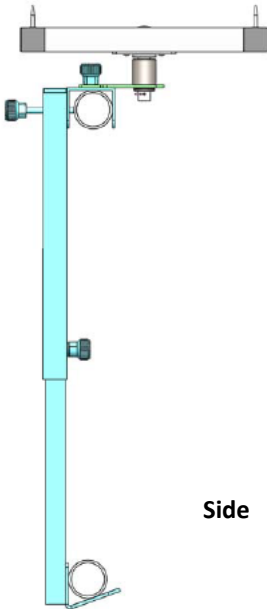
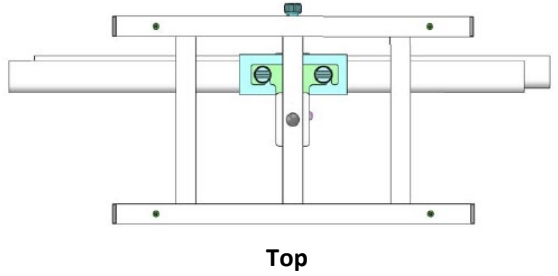
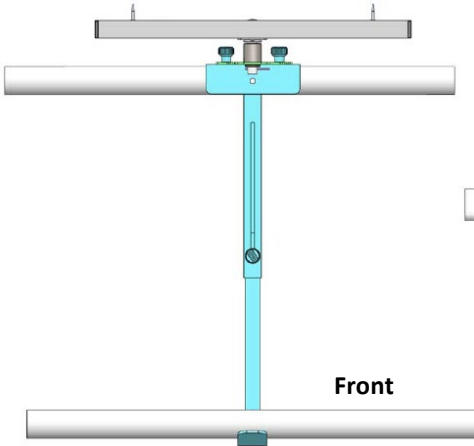

1-844-TT-TOOLS
www.tapetech.com

TapeTech Tools
1327 Northbrook Parkway, Suite 400
Suwanee, GA 30024