

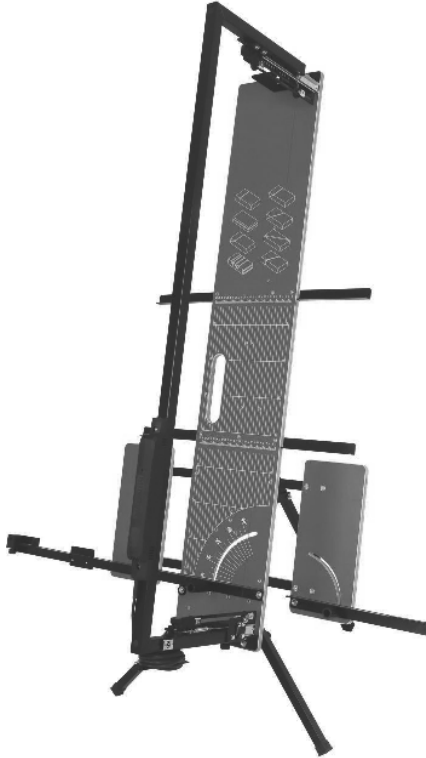

EHWJS100

Portable Hot Wire Foam Cutter



Please read these instructions carefully before operation.

Take note of the safety prompts in these instructions to avoid injury to yourself, other people and objects. Please follow the guidelines in these instructions to avoid damage to the tool.

Caution: Use outdoors or in a well-ventilated space

NOTE: The Power Switch is designed to be manually activated before and throughout the cutting process for each cut. It should never be placed in a fixed "ON" position using tape, wire ties or other devices.

DO NOT TOUCH HOT WIRE WHEN WORKING!!

1-844-TT-TOOLS
www.tapetech.com

TapeTech Tools
1327 Northbrook Parkway, Suite 400
Suwanee, GA 30024

EHWJS100 Key Components

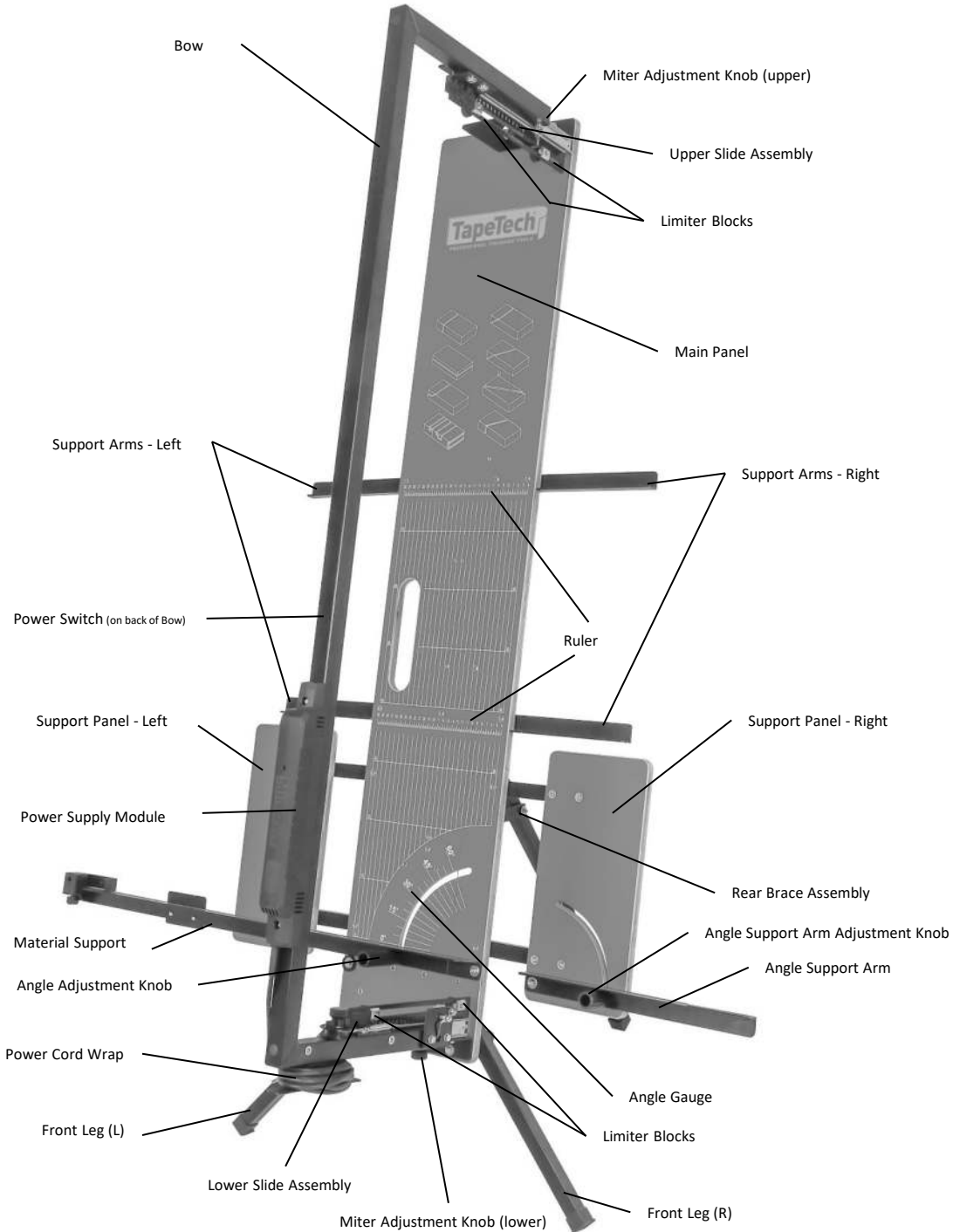

Set Up

1. Attach Front Legs to back of Main Panel

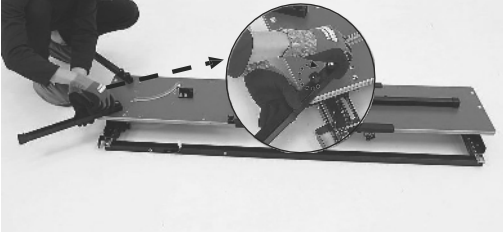

2. Set Rear Leg Assembly



3. Attach Power Module to front of Bow with M6 screws (provided)



4. Adjust Side Support Arms



5. Loosen Miter Adjustment Knobs and Rotate Bow into position

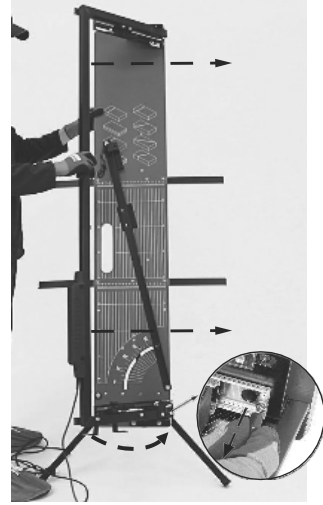

6. Loosen Angle Adjustment Knob and lower Material Support

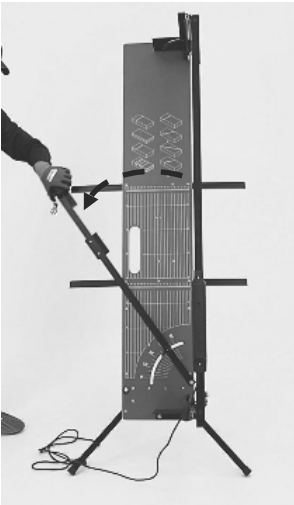

7. Attach Side Support Panels

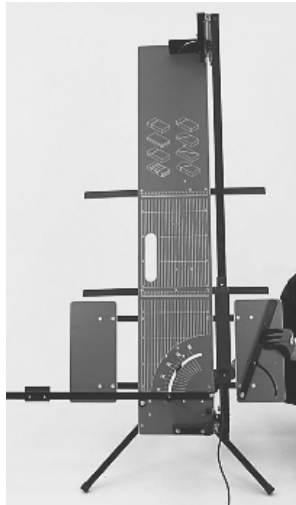

8. Connect Power Cable to Bow



The **TapeTech EHWJS100 Portable Hot Wire Cutter** is a professional-grade hot wire cutting machine for EPS/XPS foam. The hot wire heats up in seconds upon activation of the power switch.

Recommended Use

The EHWJS100 is designed to quickly and cleanly cut Expanded Polystyrene (EPS) and Extruded Polystyrene (XPS) foam.

Installation of the Hot Wire

WARNING: Always unplug the power cord of the EHWJS100 before installing or changing the hot wire. Allow sufficient cooling time for the hot wire and the springs.

1. It is recommended to use only TapeTech replacement hot wires. Part #: EHW100
2. Hook end of hot wire on to the end of the spring located on the upper slide assembly.
3. Guide the wire over the top rollers, and then around the bottom rollers, connecting the other end of the hot wire to the spring on the lower slide assembly.
4. While lifting up on the red knob, turn the knob to tighten the wire, then tighten the screw.

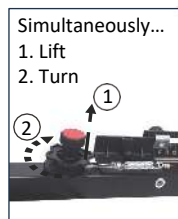

CAUTION: The wire does not need to be red hot to cut the foam. Excessive power output and heat generation may cause damage to the transformer.

Using the Scaffolding Buckle

The TapeTech EHWJS100 comes equipped with a quick-connect buckle to secure the unit to scaffolding or staging. Open the buckle and wrap the web strap around the scaffold or stage structure. Close the buckle and tighten the strap.

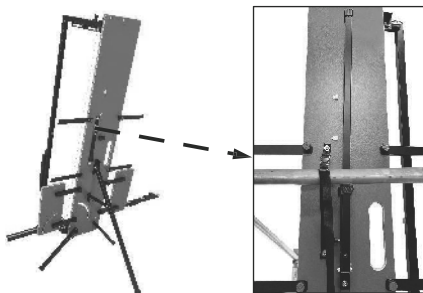

Cutting Foam Shapes

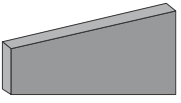
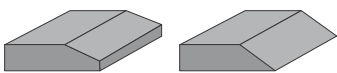
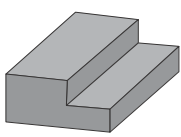
<p>Rectangle</p> 	<ol style="list-style-type: none"> 1. Set the Angle Adjustment to 0°. 2. Set the Miter Adjustment to 0°. 3. Use the Rulers to cut foam to required length.
<p>Angled Cut</p> 	<ol style="list-style-type: none"> 1. Set the Angle Adjustment to the required setting. 2. Set the Miter Adjustment to 0°. 3. Use the Ruler to cut foam to required length.
<p>Bevel Cut</p> 	<ol style="list-style-type: none"> 1. Set the Miter Adjustment to required setting. 2. Set the Angle Adjustment to 0°. 3. Use the Rulers to cut foam to required length.
<p>Step Cut (Rabbet)</p> 	<ol style="list-style-type: none"> 1. Set the Miter Adjustment to 0°. 2. Set the Angle Adjustment to 0° 3. Set the Depth Limit Blocks to required depth. 4. Use the Rulers to make vertical cut at required measure and depth, then move foam horizontally to complete step cut.

Cutting Grooves

The EHWJS100 can quickly and cleanly cut square-edged grooves in the face or the edge of EPS or XPS foam panels. To cut grooves, you will need to use the Limiter Blocks located on the Upper and Lower Slide Assemblies. The blocks are easily positioned to set the depth of cut using the ruler on the slide assemblies. NOTE: Always synchronize the position of both the upper and lower Limiter Blocks to ensure the bow stops uniformly across its length.

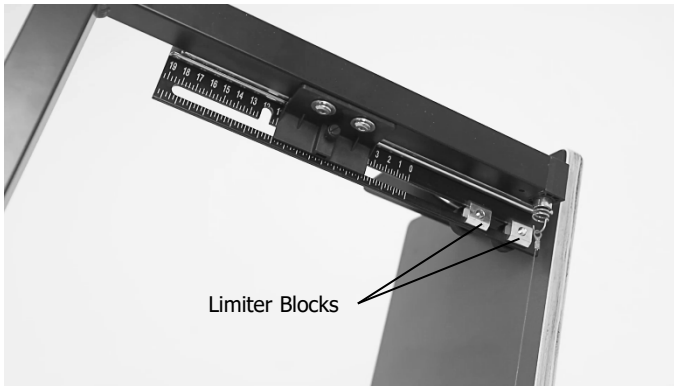

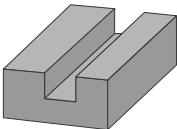
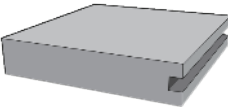
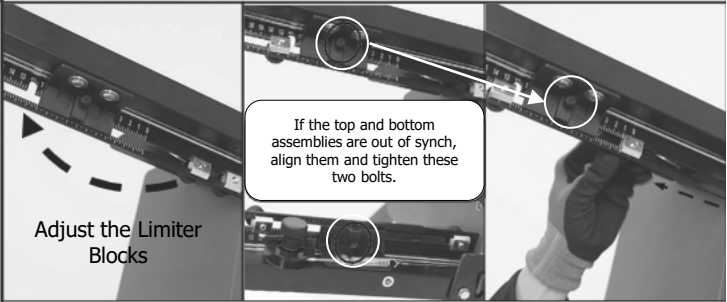
<p>Face Groove Cut</p> 	<ol style="list-style-type: none"> 1. Set the Angle Adjustment to 0°. 2. Set the Miter Adjustment to 0° 3. Set the Limiter Block to the required depth of the groove 4. Use the Ruler to cut first side of groove at required position. The limiter block will stop the wire at the bottom of the groove. 5. Move the foam board horizontally to cut the bottom of the groove to the required width. 6. Pull the bow towards you to complete the face groove cut.
<p>Side Groove Cut</p> 	 <ol style="list-style-type: none"> 1. Set the Angle Adjustment to 0° 2. Set the Miter Adjustment to 0° 3. Set the two Limiter Blocks on the upper and lower slide assemblies to control the position of the side groove based on the thickness of the material and groove requirements. 4. Rest the slide assembly against the inner Limiter Block. 5. Activate power switch and move the foam horizontally into the hot wire to create the first side of the groove. 6. Pull the bow towards you to complete the side of the groove. 7. Move the foam horizontally to complete the groove and exit the foam.

Technical Data

Model Number	EHWJS100
Max. Cutting Height	50.8" (1290 mm)
Max. Cutting Thickness	13" (330 mm)
Rulers	Left: 39" (1000 mm); 0-60° / Right: 15" (400 mm)
Net Weight	30 pounds (13.5 kg)
Assembled Size	63" x 17" x 8" (1610 X 440 X 200 mm)
Power Supply	110V
Replacement Hot Wire	EHW100
Hot Wire Temperature	Max 932°F

GENERAL SAFETY

Consider the work environment

- Do not expose tools to rain.
- Do not use tools in damp or wet locations.
- Keep work area well lit.
- Do not use tools in the presence of flammable liquids or gases.

Keep other persons away

Do not let persons not involved in the work, especially children, touch the tool or the extension cord and keep them away from the work area.

Store idle tools

When not in use, tools should be stored in a dry, secure place, out of reach of children.

Do not abuse the cord

Never yank the cord to disconnect it from the outlet. Keep the cord away from heat, oil and sharp edges.

WARNING:

1. Before servicing and changing hot wire, disconnect tools from the power supply.
2. To prevent damage to the tool it is recommended to use only authentic TapeTech replacement hot wires for the EHWJS100. Part #: EHW100
3. Please use only qualified service technicians to service or repair the tool.

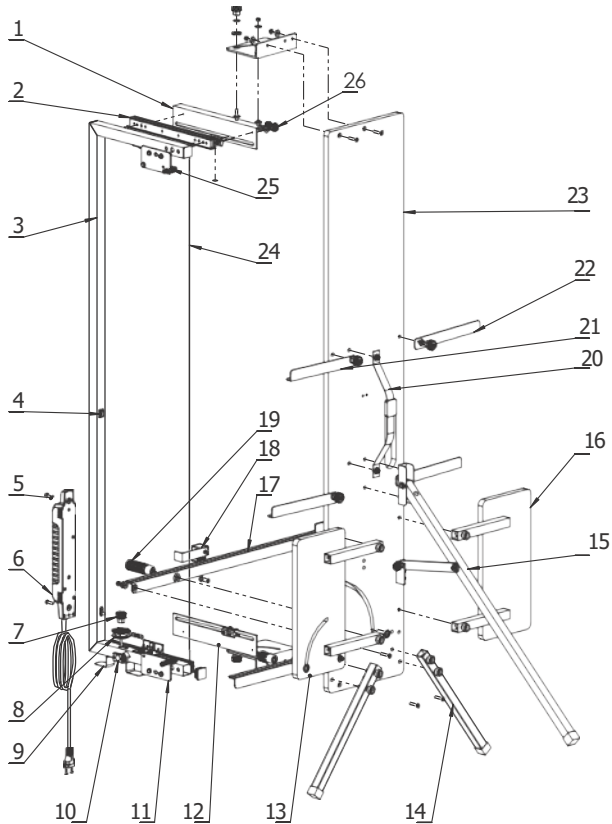

Spare parts list:

- | | |
|-----------------------------------------|---------------------------------|
| 1. Upper sliding rail corner component | 14. Front leg |
| 2. Upper sliding rail | 15. Rear brace assembly |
| 3. Bow | 16. Support panel assembly (L) |
| 4. Power Switch | 17. Material support rail |
| 5. M6 screw | 18. Switch limit dial indicator |
| 6. Power supply module output cable | 19. Adjustment knob |
| 7. M6 extended nut | 20. Scaffolding buckle assembly |
| 8. Wire rope pulley assembly | 21. Support arm (R) |
| 9. Wire winding component | 22. Support arm (L) |
| 10. Transformer outlet | 23. Main panel |
| 11. Lower roller assembly | 24. Hot wire |
| 12. Lower sliding rail corner component | 25. Lower roller assembly |
| 13. Support panel assembly (R) | 26. Limiter block |